

U. S. Postage Paid
Permit No. 320
Menlo Park Cal.

To: _____

Return Requested:
P.A.A.R.A. P.O. Box 911
Menlo Park, Cal.
94025

PALO ALTO AMATEUR RADIO ASSOCIATION, INC.



P.O. BOX 911
MENLO PARK, CALIF. 94025
A.R.S. W60TX J.E.B.

STATION W60TX

AFFILIATED CLUB

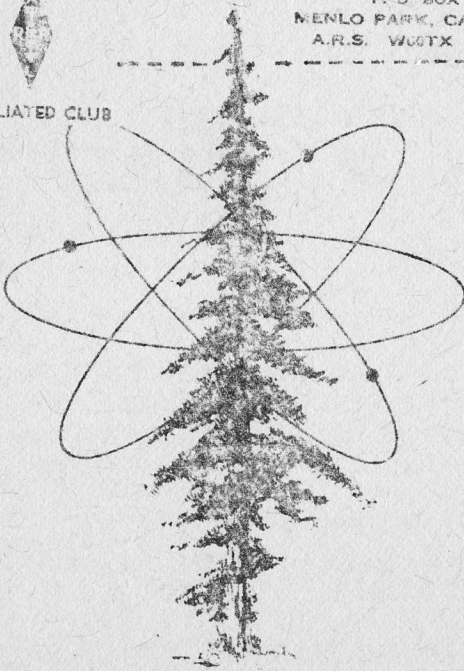

AFFILIATED CLUB

MENLO PARK
CIVIL DEFENSE
RADIO CLUB



CITY OF
MENLO
PARK

K6YQT

P
A
A
R
A

G
R
A
P
H
I
C
S

Vol.
XVII
1973

July '73

OFFICERS

PALO ALTO AMATEUR RADIO ASSOCIATION, INC.

ADMINISTRATIVE

President: Fred Canham, K6YT
 Vice Pres: Bob Baum, W6BFH
 Secretary: Gene Reynolds K6QOM
 Treasurer: Vance Wardlow W6FLE
 (Trustee W6OTX PAARA Club
 Am. Radio Station)

BOARD OF DIRECTORS

Chairman: Fred Canham, K6YT
 Sect'y : Gene Reynolds K6QOM
 Member : Hal Moore, W6DEF
 Member : Ed Fairbanks W6AIN
 Member : Andy Korsak VE3FZK
 Member : Paul Thekan (NC)
 Member : Tom Ohlsson WB6KQZ

Menlo Park C-D Radio Club

OFFICERS

President: Fred Canham, K6YT
 Vice Pres: Eric Reese, WB6KQX
 Secretary/Treasurer: Vance Wardlow, W6FLE
 Property Custodian: Bob Allen, W6WQD (Trustee K6YQT)
 Asst Property Custodian: Steve Montoya, WN6DQT
 RACES Radio Officer: Bob Allen, W6WQD
 Asst RACES Rdo Off.: Vance Wardlow, W6FLE

PAARAGRAPHS

Staff

Managing Editor: Lee Zalaznik, WB6BJB
 Ass't Editors : Andy Korsak, VE3FZK; Gene Reynolds K6QOM
 Eric Reeze, WB6KQX; Tom Ohlsson, WB6KQZ; Gene Sussli,
 WA6NVU (San Carlos Bugle).

POLICY

1. Membership includes subscription to PAARAGRAPHS;
2. Annual dues \$4.00 per year;
3. Members will be dropped upon non-payment of dues;
4. Subscription to PAARAGRAPHS \$1.00 per year; non-subscribers will be dropped from mailing list as new names are added.

APPLICATIONS FOR MEMBERSHIP

Send \$4.00 dues to PAARA, P.O. Box 911, Menlo Park, Ca. 94025
 For info call 854 0803

JOIN THE CLUB

BECOME A PARTICIPATOR

GET INVOLVED

COMMING EVENTS

FIELD TRIP - On Friday 6 July all Club members and their guests are invited to participate in a Field Trip to Radio Station KGEI, the Voice of Friendship. The station is owned and operated by the Far East Broadcasting Company. It beams programs of educational, cultural and christian content to all Latin American Nations. The broadcasts are made daily starting at 3:30PM PST on the assigned frequency of 15,280Mhz. Take a listen.

All those wishing to participate in the Field Trip should meet on the parking lot of the Marine World, on Marine World Parkway just off Bayshore Freeway at the northern edge of Redwood City. Assembly time is before 7:30PM. At that time the group will proceed in caravan to the Radio Station. There we will assemble in the conference room for a brief general meeting and description of the Station functions. Arrangements for the tour of the Station were made through Mr. Jack Brooks.

Anyone missing the caravan may proceed on Marineworld Parkway to Bridge Parkway, turn left and proceed to Peninsula Parkway, turn left and go to Shell Parkway, continue until you see a sign identifying KGEI and KNBR - proceed to the building of KGEI. And if you get stuck in the mud get on you mobile rig and get a call through to 591 7374 - they will provide moral support in your perdicament!

* * * * *

BOARD OF DIRECTORS MEETING - Will be held in the Trailer at SRI at 7:30, Wednesday 11 July. The results of the Field Day competition will be discussed. There will be a critique of events. All members invited - bring your critique.

COMING EVENTS (Cont'd)

4th OF JULY PARADE - The annual Redwood City's Fourth of July parade is a big event in and on the Peninsula. The Peninsula Celebrations Association is the sponsor and the Redwood City Civil Defense and Disaster Communications Net handles the necessary details of assembling and the resolution of emergencies which may occur during the parade. It provides the Base Control Station, W6WWJ, and eight portable stations each with operator and messenger. The communications group assembles at Arguello and Whipple Streets in Redwood City at 8:30AM, station locations are assigned and communications are established. The parade usually lasts about an hour.

Anyone able and wishing to participate should contact Hal Moore, W6DEF, phone 368 0444. In the past many years this net has been of great assistance to the Parade Master in the scheduling of parade units and in the resolution of emergencies. BECOME A PARTICIPATOR! ! ! !

Andy Korsak, VE3FZK, and Paul Thekan will eventually get to the project of getting the laticework tower designated as available by Hal Moore, W6DEF. They will soon mount it on top of the steam building with a special ATV antenna for Andys project. They will at the same time get the two antennas moved from the main building of SRI to the steam plant with appropriate coax feeders to provide the trailer with an excellent selection of antennas. GET GOING FELLERS ! ! !

Oliver Sweningsen jr., WA6QGX, will deliver the 5KW Generator to the trailer site as soon as he gets PG&E power to his new QTH. The overhaul and dress-up project will start at that point to provide the Club with an A-No.1 power unit which will take care of any emergency. In the mean time we are looking for a light boat trailer on which to mount it and make it trully mobile. Both Glen Bakers and Fred Canhams trailers are being used as intermediary means of moving the unit to field locations.

THE CLUB WILL BE OVERWHELMED WITH VOLUNTEERS FOR THE VARIOUS PROJECTS FROM OUR LIST OF TRUE PARTICIPATORS! ! !

5
NOTICE NOTICE NOTICE

NOTICE TO ALL MEMBERS AND SUBSCRIBERS - THIS IS THE LAST ISSUE OF PAARAGRAPHS IN ITS' PRESENT FORMAT. THERE WILL BE A COMPLETE CHANGE IN EDITOR AND EDITORIAL STAFF BEGINNING WITH AUGUST 1973. DECISIONS ON THESE ITEMS HAVE NOT AT THIS TIME BEEN MADE. OUR PRESIDENT, Fred Canham, K6TV, WILL COORDINATE AND DIRECT ALL EFFORTS TOWARD MAINTAINING A MONTHLY PUBLIC_{ATION} FOR THE PALO ALTO AMATEUR RADIO ASSOCIATION AND THE MENLO PARK C-D CLUB.

* * * * *

At this time we want to say a few words in praise of the very fine work done by Lee Zalaznik, WB6BJB, in assuming the editorship of PAARAGRAPHS at a time when it appeared there must be a cessation of publication. Lee took the job under very adverse conditions. He was at the time in the process of moving from Palo Alto to Pleasanton. For the past year he has continued the excellent job under the handicap of being across the bay from the scene of operations of the Club. By dint of many phone calls, much commuting back and forth and coordination with those who were able to volunteer some help in the very demanding job of preparing the paper Lee has maintained a very high level of readership and has produced an excellent paper every month - meeting all deadlines!

We are very much indebted to Lee for all this fine work and will greatly miss his cheerful acceptance of an odious job. Every member of the Club owes Lee a vote of thanks.

We also want at this time to thank our subscribers who have been so faithful in supporting the Club paper over these past years. We have tried to give them full value for their advertising dollars and continue to urge our members to go to our advertisers for their needs. However we recognize that it takes a lot of faith on the advertisers part to pay out their money on the hope that the ads will draw sufficient numbers to make it a paying business proposition. To each and every one we submit our sincere thanks for their support and assistance in making it possible to publish PAARAGRAPHS over the past several years.

REPORT OF LAST MEETING, 1 JUNE 1973:

The program for the evening was a demonstration by Andy Korsak, VE3FZK and Wayne Ryder, W6URH, of Amateur Color TV.

Fred Canham, President of PAARA opened the meeting by distributing several name tags which had been ordered by various members. (If you have ordered one Fred may have it, if you want one tell Fred).

Jerry Starkey, WA6LIJ, announced a number of names of those who will participate in Field Day on his team using 20 and 80 Phone. He announced a number of awards to be given to members participating on Field Day. They include

- 1) Most points by any operator during any one hour period;
- 2) Most points by any one operator during the whole period;
- 3) most foul-ups and loss of points by any one operator!

Fred will captain the CW station, Lee Zalaznik the 15-40 station, Paul Thekan will captain the Novice station.

Fred announced that a meeting would be held Wednesday evening at 7:30 at the Trailer to discuss the antenna layout and station organization. He explained the Field Day rules as they relate to the competition between local stations and coordinated by CCRC.

Fred showed several slides of the Field Day operation of AMPEX at Huddart Park in 1970. Several were really beautiful while others had very nice detail about the various installations by that Club.

Visitor Millard Edgerton, WA6VZZ was introduced.

Andy and Wayne had assembled a very impressive array of various ATV instruments and devices. They proceeded to demonstrate their operability and explain their various functions. By block diagram and detailed circuitry they explained the function of each "block" and mentioned some of the various "gremlins" encountered. A VERY INTERESTING EVENING!!!

BOARD OF DIRECTORS MEETING, ⁷Trailer SRI, 6 June 1973:

Eight members present. Meeting called to order at 7:30 P.M..
Financial report was given.

Fred Canham, K6TV, outlined the very successful participation of the Club in 2 "Exploratoriums" held at the Eastbrook and Portola Schools in Los Altos. Fred, Jerry Starkey, WA6LIJ and Ed Fairbanks, W6AIN, assisted others in setting up an amateur station at each school. Contacts were made with various other hams and the children were allowed to talk over the air. About 90 to 100 children were thus introduced to the world of Ham Radio. Jerry Holter of the Foot-hill Club and Larry Reed of San Carlos also participated.

Hal Moore, W6DEF, announced that Ralph Trout, WA6EGH and his wife Rachel, WA6EQA, had volunteered to operate and maintain the Red Cross Station W6OTR. The Board voted an expression of gratitude to the Trouts for their assistance.

Jerry Starkey, WA6LIJ, broached the subject of the lattice tower available according to Hal Moore. Some discussion - no decision.

Andy Korsak, VE3FZK, brought up the subject of the next meeting program. Bob Baum, W6BFH, mentioned that he would be unable to assist in the tour of the Weather Station at Redwood City on 6 July. Andy suggested a trip to KGEI in lieu of the weather station. All agreed.

In view of past experiences with the San Carlos Club and their failure to produce promised actions the Board agreed that Andy Korsak will discuss with them the possibility of discontinuing the past arrangement whereby PAARA depended upon them to arrange for meetings, produce a page for our PAARAGRAPHS and other functions.

Andy announced that San Carlos has 100 operators available for Field Day! Some skepticism expressed!

Jerry Starkey outlined plans for awards on Field Day.(Cont'd)

RJ

⁸
"Red" Johnson ELECTRONICS

440 PEPPER

· PALO ALTO, CALIFORNIA ·

326-6085

NEW
SPECIALS
→
↙ ↘

Tantalum
Capacitor
Specials ↘

33 MFD. - 10VDC. - 30¢

47 MFD. - 6VDC. - 25¢

68 MFD. - 2.0VDC. - 85¢

Impulse
Counter

6-Digit
110 VDC. \$2⁰⁰



Veeder-
Root

HAYDON
Timer

27VDC.
1½ - 2½ Min. (Adj.)

DROP IN-
LOOK AROUND

M-F: 8AM-8PM,

Sat.: 8AM-6PM,

Sun.: 10AM-2PM.

Adjustable
Delay Line

Z = 1000Ω

T_d = 0 to 0.4 μsec

\$5⁰⁰
un

BOARD OF DIRECTORS MEETING (Cont'd)

Jerry Starkey pointed out that QUEMENT RADIO has a 60 ft. tower mounted on a trailer which might be available for Field Day. He will investigate. Jerry outlined the number of hours he has been putting in on Ham Radio activities. He has put in more than 100 hours. He also complains that he is spending money in small lots for various things. He does not intend to continue either of these. He suggests that each Team Captain be allotted a sum of money to expend on Field Day. He also suggests a series of awards for participators.

After much discussion there was no agreement by the Board members regarding these suggestions. The problem was reassigned to the Awards Committee for further study.

Hal Moore asks what time the Teams should assemble on Friday for station preparation. The Board instructed that this was a decision for each Team Captain.

Lee Zalaznik, WB6BJB, announced his resignation as editor of PAARAGRAPHS. He suggested that the President determine future publication policy. The Board passed a resolution of thanks to Lee for his excellent work over the past year.

There was much discussion of alternatives to assure the continuation of PAARAGRAPHS as the Club organ. Vance Wardlow W6FLE, suggested it be coordinated with the EMARC Foothill College paper. This would provide a responsible base from which the paper could be correlated and published. Some Board members felt very sure this would not be feasible.

Meeting adjourned at 10PM.

* * * * *

Am in receipt of a very nice letter from Charles Proctor, 356 Morse Ave., Sunnyvale, Ca. 94086 in which he says he has lost his sight due to cataract and glaucoma. As a result he was unable to keep up his novice license and lost it in 1971. He now wants to renew his novice license and study for a general. He has a transportation problem and needs help from someone to get to a novice class and to the FCC office. Anyone able to assist call Charles at 739 2784. His old call was WN6NQY.

BECOME A PARTICIPATOR - HELP A FELLOW HAM

23-24 June 1973

FIELD

And so it came about that FIELD DAY occurred after long and arduous work in the vineyards. The antennas, tents and spirits rose as the sun sank into the west.

AND HERE ARE THE PARTICIPATORS

CW

15 - 20 - 40

Fred Canham, K6YT, Capt
Les Vickery, W6AKR
Hal Moore, W6DEF
Fred Diedrich, W6MOH
Mike Eccles, G3PPE

PHONE

15 - 40

Lee Zalaznik, WB6BJB, Capt
Ed Fairbanks, W6AIN
Rich Ferranit, WA6NCX
Mike Eccles, G3PPE
Milt Donovan, W6MFN

SUPERNUMARIES

All Bands

Dave Harper, WB6JFH
Walt Harper
Vance Wardlow, W6FLE
Oliver Sweningsen jr. WA6QGX

PHONE #1

20 - 75

Jerry Starkey, WA6LIJ, Capt
Terry Conboy, WB6GRZ
Dick Laird, WN6FZM
Bob Baum, W6BFH
Eric Reese, WB6KQX
Fred Wideman, W6KKN
Paul Churchill, W6QBY
Dick Finkbeiner, W6AQL
Mike Cooley, WA7AUA

NOVICE

Call WN6SSR

Paul Thekan, Capt
Bruce Wilbur, WN6SSR
Steve Montoya, WN6DQT
Rob Walker
John Cameron

Visitors

George Raven, K6OG
Millard Edgerton, WA6VZZ

And there you have the crew which proved that PAARA has the ability, initiative, drive and knowhow to set up and operate a Field Station. It took a lot of prior planning, hard work and coordination to get all the required materials and equipment together, delivered to the site and set up as four operating stations. These PARTICIPATORS proved again that team work pays off in big dividends.

THEY MADE THE HIGHEST SCORE IN MANY YEARS

Congratulations to all! ! Our Club members can be proud.

DAY

Sharron Heights, Menlo Park

Of all the initiative, improvisation, originality and general good sense demonstrated on this Field Day the blue ribbon must go to our crew of NOVICES. With the minimum of prior experience they proceeded to set up the ONLY novel, new and effective antenna system. They, on their own, set up a 60 foot mast with a 20 foot cross bar on which they mounted a 40 meter Quad! Using guidance from QST the result was a very efficient beam. Topping it all, 20 feet above the mast they mounted an american flag - it could be seen for many miles around the valley. CONGRATULATIONS ! ! ! They then proceeded to rack up a score of 97 contacts! !

The #2 Phone team captained by Lee Zalaznik started out somewhat disorganized. However with a little assist here and there Lees team got the antennas up, the tent erected and the sets installed. Once in operation the expertise of this team began to show results. By judicious spelling of the watches by each they racked up a score of 297 contacts.

Our CW station captained by Fred Canham was erected with the obvious skill which comes from long experience. Every needed part and item was available so no delays or foulups occurred. The sets were installed and operated at the turn of the switch. Contacts got off to a slow start due to conditions. However as the day wore on conditions improved and contacts began rolling in. Expert manipulation of the hand key and bug and with big assistance from excellent loggers the points began to pile up. End result 325 contacts.

An excellent demonstration of proper planning and organization resulted in our #1 Phone station running like clock works. Jerry Starkey captained this team and each member of his team had been selected and assigned according to their best potential. Jerry brought along his crank-up mast and mounted his beam on it. It proved to be a most efficient way of getting a signal squirter up there where it would do the most good. He had all the needed items available right down to the soft drinks! And you can be sure these were apprec-

FIELD DAY(Cont'd)

iated. Each team member both operator and logger got right into the spirit of the contest. There was a fine demonstration of mutual assistance to assure the maximum of contacts with the minimum of "repeats". Jerry had set up a series of awards for optimum efficiency. Here is the way the awards were assigned:

OPERATORS

Most contacts on 75M:
 Terry Conboy - 123
 Most contacts on 20M:
 Jerry Starkey - 152
 Most contacts on FIELD DAY:
 Mike Cooley - 190

LOGGERS

Most entries on 75M:
 Terry Conboy - 138
 Most entries on 20M:
 Terry Conboy - 170
 Most contacts per hour(2hrs):
 Terry Conboy - 55 per hr.

Total contacts on 20M 470, on 75M 261

GRAND TOTAL 731

All the above figures have been subjected to a preliminary screening for repeats and errors. They are unofficial.

Our supernumeraries were kept busy lending a hand here and there when a strong back was needed, garbage was to be removed, water carried and gasoline procured.

Oliver Sweningsen jr. came through beautifully with the big generator. Had it hauled down from his ranch in Contr Costa and delivered to the site. It worked fine without ever missing a stroke throughout the Field Day.

Dave Harper was there overseeing the whole operation and making good suggestion in the solution of problems. His dad Walter was a real genius at finding and solving problems of where to put the guy wires and drive the stakes.

Vance Wardlow hung around, greeted the visitors and in general got in the way.

Our visitors George Raven and Millard Edgerton were promptly put to work - they will learn that PAARA takes Field Day seriously! Nice to have had you aboard and thanks.

A GOOD TIME WAS HAD BY ALL SUCCESSFUL FIELD DAY

LET'S DO IT AGAIN NEXT YEAR - AND DO IT BETTER ! ! !

J & H OUTLET

SURPLUS ELECTRONICS INTEGRATED CIRCUITS

TRANSISTORS — DIODES — TUBES — METERS — RESISTORS
AND MANY OTHER ITEMS TOO NUMEROUS TO LIST HERE

AN UNUSUAL DISPLAY OF NEW AND SURPLUS ITEMS

ALUMINUM, BRASS, COPPER, STAINLESS STEEL
in sheets, bars, blocks, rods, tubes, shapes, etc.

STORE HOURS:
MONDAY THROUGH SATURDAY 10 AM TO 6 PM

— LOOK FOR US AT —

476 INDUSTRIAL WAY

Corner
Industrial &
Holly

Phone 591-7113

San Carlos 94070

AN UNUSUAL DISPLAY OF NEW
AND SURPLUS ITEMS

ALUMINUM, BRASS, COPPER, STAINLESS STEEL
IN SHEETS, BARS, BLOCKS, RODS, TUBES, SHAPES, ETC.

STORE HOURS
MONDAY THROUGH SATURDAY 10 AM to 6 PM

J&H OUTLET
476 INDUSTRIAL WAY SAN CARLOS CA. PHONE 591 7113

OUR PARAPETITIC PARTICIPATORS

By the time you read this Andy Korsak, VE3FZK, our ATV expert, Club junk box retainer and "far out" project innovator will be back from a trip to British Columbia. He and his wonderful family loaded up the Datsun and took off. He had hoped to make contact back home with Bob Baum and Ed Fairbanks but so far no luck. We missed Any on Field Day with his unbound enthusiasm and many innovations. As some poor demented soul remarked at the site "Our high score this year may be partly due to Andys' being on a trip"!

Hal Moore and his beautiful XYL recently made a flying trip to Europe - saw many lands, visited many historical spots and generally enjoyed themselves. Hal prepared a travelogue which is beautiful, sounds like a report by Marco Polo! Thanks Hal.

Irv Wolfe and his pretty bride of many years are also off on a tour of Europe including a jaunt to Moscow. Haven't heard from them but am sure they will have a wonderful time of it and have many tales to tell when they return.

Steve Montoya, who did a fine job on the Novice station Field Day, is off on a back packing trip in the Sierras. He expects to on the trail about 15 days and cover many miles of the Muir Trail.

Tom Ohlsson, with his family, are off on a tour on Denmark. Will be gone several weeks and visit many friends. By the time Tom gets back we will probably have to talk to him in Danish!

Lee Zalaznik took a 2 week vacation visiting his folks near Eureka. Got in some fishing and a lot of hiking. Now he feels he can stand the rush a bustle of Pleasanton for a few more months! Nice going Lee - now settle down and get that station of yours on the air! And watch that new digital clock to be sure time doesn't run out!

JOIN THE CLUB

BE A PARTICIPATOR

TECHNICAL TOPICS de Andy Korsak VE3FZK/W4

Typing this article is the last thing I have to do before getting on the way to British Columbia (VE7 land) — the camper is all outfitted, the kids are bugging me to get going already, and I just have to fulfill my responsibilities to my glorious radio club!

I will be mobile on 20, 40, and 80 and made skeds with Bob W6BFH Vance W6FLE and Ed W6AIN starting out on 14,275 at 0300z and if no good then at or near 7255 abt 0310 and if that's no good then on 3952 at abt 0320Z, and if that's no good, I'll give up (no more bands in my NCX-3). My vacation is from June 16 till July 1.

I just slapped together another intercom system in my camper. The previous system consisted of a 3-watt Callectro a.f. amp wired thru a switching system to a couple of cheap speakers, and I never could get rid of the feedback so last year on my mobile trip across the USA I copped out and bought a pair of Realistic walkie-talkies. These worked fine till the kids got hold of them and busted off half the antenna on each one. Have you ever seen a kid hold a walkie talkie that didn't have the antenna busted off? If you did, I'll eat my words! Anyway, this time I'm falling back to the experience of trusty old "Maw Bell". I hooked up an ordinary telephone in the camper and a telephone operator type headset in the cab, so the driver doesn't have to take hands off the wheel and can converse two ways. The only time the driver has to do anything is to push a normally off microswitch I pulled out of the club kitty and wired in series with the two sets, when wanting to ring the bell of the phone in the camper so as to keep down battery drain and have the camper unit hung up unless talking. Telephones don't work well with less than 24 volts, so I am using an old telephone battery in series with the car battery. So far it works fine, but I haven't tried it under high noise driving conditions.

Converting 11 Antennas for Two Antennas

By Rick Corrotti

About everyone has an old all-aluminum antenna line around — the one you get for the 10-15 ft. (especially 10, 20 or 30 ft. long). So you have

on most is about 6 feet, and the three low-band elements on the typical "three by three" low- and high-band antenna can be cut down to make three longest elements for the two-meter Yagi. Save the "delta" arms of the original array -- they are long enough for the remaining two directors. Also the insulating block is good for the driven element -- it must be a split dipole with "L" match.

The antenna should be vertically polarized so mount all elements using the original hardware and drilling out rivets, along a plane perpendicular to the mounting "U" clamp. Because of the vertical orientation, you must use an insulating support for about the first three feet, after which conventional TV mast can be used. This is best done by good old PVC pipe, capped at the top and stuffed (for greater stiffness) with a dowel rod fitted to the inside diameter of the pipe.

The matching is accomplished by W4KAB's idea given in the last page of the VHF manual -- the direct coax-fed "L" match. Dimensions are given below, and all that is necessary for a good match is a decent SWR bridge.

Good luck--CU on 2 -- NCX

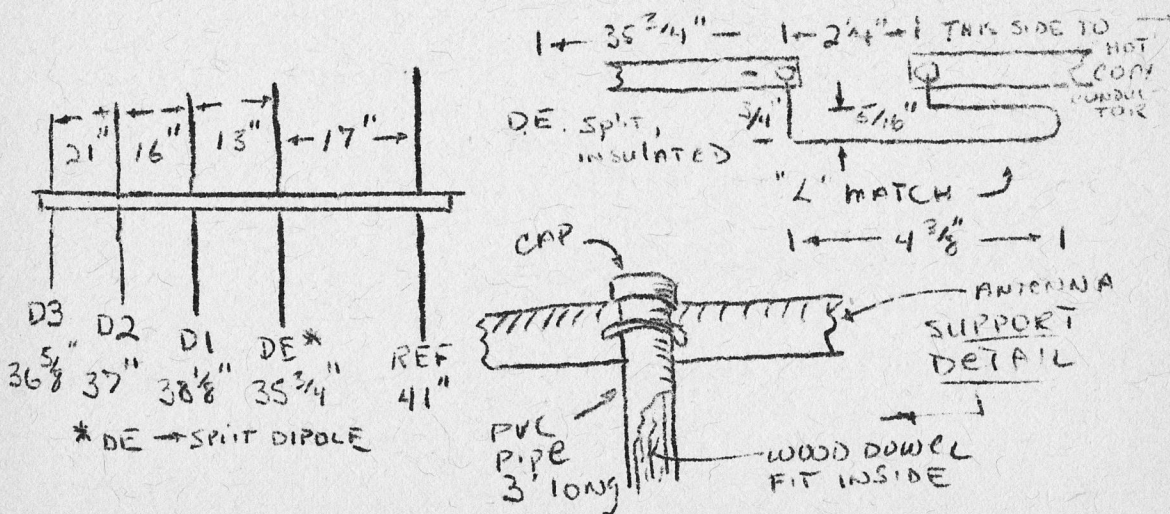

IMPOSTERS

You have all read the story of the "Rattlesnake" by K2YAH back in Monroe County and how it turned out to be a "CB'er" with no license and lots of power. He was caught and convicted.

Now we have a case closer to home. It appears that George "Blackjack" Leer, of San Jose has been found guilty of illegally using the Citizens Band and interfering with neighbors TV sets. He had earlier lost his CB license and had \$5000.00 worth of equipment seized for using it illegally.

The saddest part of this whole tale, as far as we hams are concerned, is that the Palo Alto Times on Monday June 25th, page 3 s ants the news item off with the statement: "An amateur radio operator has been convicted in federal court of using the citizens band illegally and interfering with a neighbors television reception of football games"!

The Times has been advised many times of the special status of "amateur radio operators". Several local amateurs have gone to great length to advise the Times that radio amateur radio operators are very conscious of their responsibilities to the public, go to great lengths to avoid any interference such as described in the article and have set up special committees to investigate any such problems. Also the Times has been advised many times that Citizen Band operators are not Amateur Radio Operators, they continue to create problems on the air waves, are practically unregulated and are known throughout the United States for their disregard of the laws and regulations for the protection of the public.

It is suggested that all members and subscribers write a letter to the Times objecting to the misrepresentation of the Ham fraternity in their article.

The Times did give us a nice writeup on Field Day in their June 22 issue also on page 3. We do appreciate this information being made available to the public which is the final beneficiary of our Field Day activities.

* * * * *

HAVE YOU SENT IN YOUR APPLICATION FOR MEMBERSHIP?
GET SNAPPING

BECOME A PARTICIPATOR

WRITE TO P.O. BOX 911, MENLO PARK, CA., Zip #94025

MORE ON OUR PARTICIPATORS (From the EMARC PENMARK)

On 18 May, Fred Canham, K6YT, Jerry Starkey, WA6LIJ, Jerry Holter, W6OCP, Ed Fairbanks, W6AIN, Larry Reed, W6CTH, Bob Wiedeman, WA6FKK, demonstrated Ham Radio at a 1 day "Exploratorium" at the Eastbrook Elementary School, Los Altos Hills. Approximately 60 students attended lectures and bounced 40 meter ions up and down the west coast from W6OTX/6 (Palo Alto Amateur Radio Association).

Bob Holmes, WA6HJP/7 operating from his house trailer near Seattle, very graciously and patiently answered questions. Questions ranged from "Watergate" to Bob's Navy Service on a destroyer during W.W. II. During the lectures, one alert young man asked, "If you say 73's this year, will you say 74's next year?"

Needless to say the instructors had as much fun as the students.

* * * * *

The 20 May motorcade to Mt. Diablo was enjoyed by all. Jerry and XYL, W6OCP and WN6LSN respectively, led a caravan from the museum, while Andy, VE3FZK/6, brought up a gang from the Palo Alto Club. Lee, WB6BJB, arrived at the summit at approximately the same time the caravan departed; Ed W6AIN, from his home QTH, helped to coordinate the trip from the local area. Hence, we had excellent communications between mobiles destination and departure points. The weather was on the cool side of the Chamber of Commerce estimates until approximately 2:00PM. Members of the San Carlos Club operated a portable station from the tail gate of the Bach Scout. Jay King, WB6QNK and Jay Hamlin, WB6HBS, put up a 40 meter dipole. Picnic lunch accompanied by the aroma of Jean's roasting marshmallows provided sustenance for the attempted Kite Flying and trek to the top of Mt. Diablo. The sun blazed through the sky and the wind almost disappeared. The view was tremendous and although a bit limited by haze, most of the State Park's claims were enjoyed by all. A two meter hand held FM rig supplemented rag chewing and sight seeing from the top of the look-out building.

* * * * *

DON'T MISS THE FUN

JOIN THE CLUB

BE A PARTICIPATOR

WRITE: PAARA, P.O. BOX 911, MENLO PARK, CA. 94025. SEND \$4

HALTEK ELECTRONICS

1690 PLYMOUTH AVE., P. O. BOX 970

MOUNTAIN VIEW, CALIFORNIA 94040

PHONE: AREA CODE (415) 969-0510

• Surplus Electronic Test Equipment & Components

Haltek Electronics

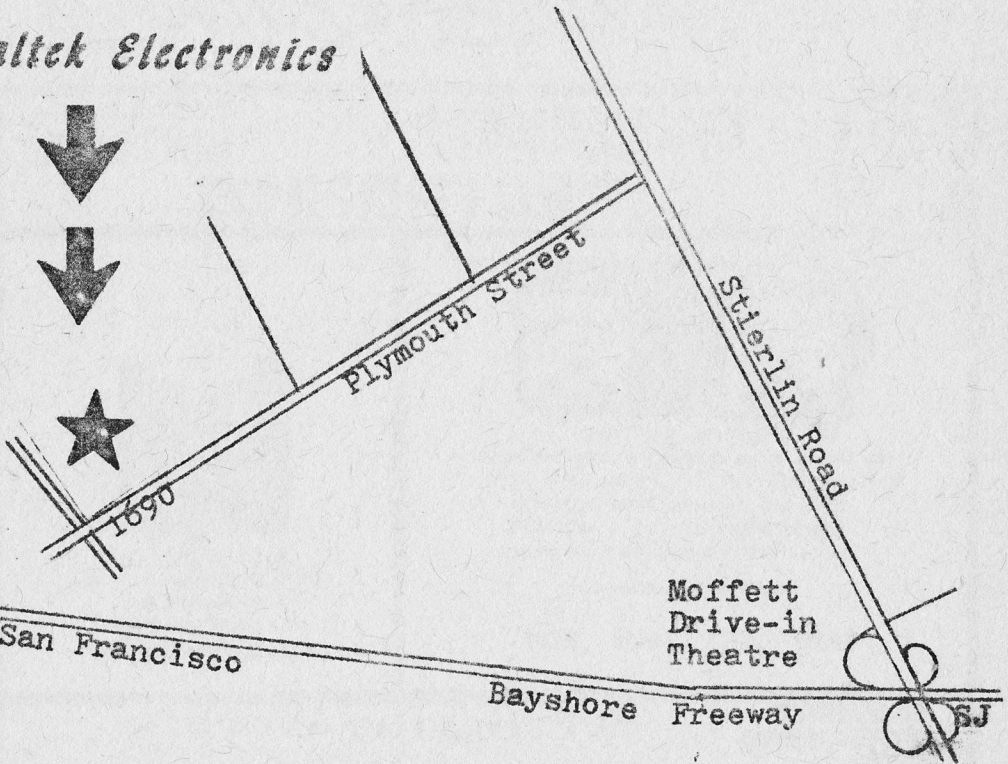

Haltek Electronics 1690 Plymouth Ave., Mountain View, California 94040

- QUEMENTS -

"WHERE YOUR FRIENDS AND NEIGHBORS TRADE"

QUEMENT



OPEN THURSDAY NITES 'TIL 9

QUEMENT ELECTRONICS
1000 SOUTH BASCOM AVE. SAN JOSE, CALIF.
"WHERE IN CALIFORNIA YOU'LL FIND COMPLETE HAM STORE"

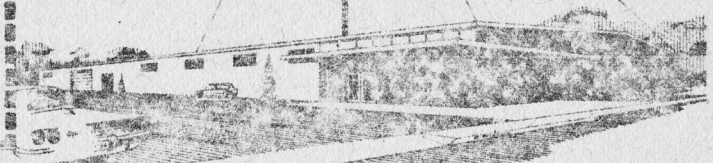

All roads lead to Qument Electronics



QUEMENT ELECTRONICS

40,000 SQ. FT. OF ELECTRONIC PARTS, COMPONENTS, TUBES AND ACCESSORIES
- AMATEUR - HAM SERVICE DEPT.
- HAM CLUBS - ACCIDENTS AND DEMONSTRATION ROOM
- CITIZEN'S BAND - COMPLETE STATION IN FIFTEEN
- COMMERCIAL AND INDUSTRIAL PARTS SUPPLY
- BANKAMERICARD - FIRST NATIONAL - MASTERCARD

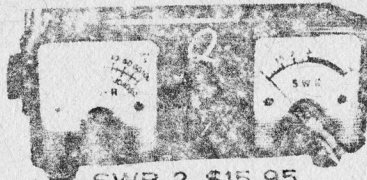

SWB-2 \$15.95

SWR BRIDGE READS FORWARD & REFLECTED POWER SIMULTANEOUSLY 'EASY READ' METERS

DUAL 100-MICROAMP METER MOVEMENTS
LOW INSERTION LOSS SIZE 5X2X2
MAY BE LEFT IN LINE UP TO 2,000 WATTS

ADD \$1.00 FOR POSTAGE

OUR BEST "HAM" BUY



MT-2 \$15.95

DELUXE 20,000 OHM-VOLT VOM WITH LEATHER CASE, TEST LEADS, & BATTERIES
ADD \$.50 FOR POSTAGE

QUEMENT ELECTRONICS
1000 SOUTH BASCOM AVE.
SAN JOSE, CALIFORNIA 95128

Serving the World's

408 998 5900 Radio Amateurs